











prestige

160 | 185 | 210 | 235 |





Marciniak KG

Landmaschinen • Gartengeräte • Ersatzteile
 Stahlstr. / am Bahnhof
 D-30916 Isernhagen HB
 Tel.: 05 11 - 730 630
 Fax.: 05 11 - 73 31 51
 E-Mail: info@marciniak-landmaschinen.de
 Homepage: www.marciniak.info

-  **IMPIEGO:** Idonea per la pulizia di banchine stradali, bordi e sponde di fossati.
-  **USE:** Suitable for cleaning quay and side of ditches.
-  **EMPLOI:** Broyeur d'accotement à grand déport pour nettoyage bord de routes etc.
-  **ANWENDUNG:** Für Pflege von Strassenrandern, Gräben und Böschungen.
-  **UTILIZACION:** Idonea para limpieza banquetas, costado foso.

MODEL	A cm	B cm	C cm	D cm	E cm	F cm	G cm	H cm	L cm	M cm	P cm	S cm	T cm	U cm	 max Ø 6/8 cm	 max Ø 6/8 cm		 Kg	 min - max
PRESTIGE 160	84	220	169	156	155	248	110	57	13	85	190	36	185	90	36	12	3	770	70 - 80
PRESTIGE 185	84	250	196	183	155	275	140	57	13	85	190	36	185	90	48	16	4	800	80 - 90
PRESTIGE 210	84	266	215	200	155	295	160	57	13	85	190	36	185	90	48	16	4	840	90 - 100
PRESTIGE 235	84	293	242	229	155	322	180	57	13	85	190	36	185	90	60	20	4	870	90 - 100

EQUIPAGGIAMENTO DI SERIE • STANDARD EQUIPMENT • DE SÉRIE • STANDARDSAUSSTATTUNG • ACESORIOS DE SERIE

-  PDF 540 G/M
CARDANO
SICUREZZA MECCANICA E
AUTOLIVELLAMENTO CON BIELLETTA
DOPPIO TELAIO
COFANO POSTERIORE APRIBILE
PROTEZIONE ANTERIORE
RULLO Ø 195
SLITTE
SPOSTAMENTO LATERALE IDR.
INCLINAZIONE IDRICA
CON VALVOLA DI BLOCCO
RUOTA LIBERA NEL GRUPPO
CUSCINETTI OSCILLANTI DOPPI RULLI
-  PTO 540 RPM
PTO SHAFT
MECHANICAL SAFETY AND
SELF LEVELLING BREAKWAY COUPLING
DOUBLE FRAME
REAR OPENED BONNET
FRONT SAFETY PROTECTION
ROLLER Ø 195
SKIDS
HYDR. SIDE ADJUSTMENT
HYDR. INCLINATION ADJUSTMENT
WITH SAFETY-VALVE
GEARBOX W/FREE WHEEL
SWINGING BEARING W/DOUBLE ROLLERS
-  PDF 540 T/MIN
CARDAN
SÉCURITÉ MÉCANIQUE
AUTO-NIVELL PAR BIELLETTE
DOUBLE CHASSIS
CAPOT AR. OUVRANT
PROTECTION AVANT
ROULEAU ARRIÈRE Ø 195
PATINS
DÉPORT LATÉRALE HYDRAULIQUE
INCLINAISON HYDRAULIQUE
AVEC SUPAPE DE BLOCAGE
ROUE LIBRE DANS LE BOITIER
ROULEM. OSCILL. à DOUBLE ROULEAUX
-  ZAPFWELLE 540 U/MIN
GELENKWELLE
ANFAHRSICHERUNG UND BODENANGLEICH
DURCH PLEUELSTANGE
DOPPLE RAHMEN
HINTERE HAUFMACHBARE HAUBE
VORDERE SCHUTZ
WALZE Ø 195
KUFEN
HYDR. SEITENVERSCHIEBUNG
HYDRAULISCHE NEIGUNG
MIT SPERRVENTIL
GETRIEBE MIT FREILAUF
SCHWINGENDE LAGER MIT DPL ROLLEN
-  TDF 540 RPM
CARDAN
SECURIDAD MECANICA Y SISTEME
AUTONIVELADOR CON BIELA
DOBLE BASTIDOR
COFRE POSTERIOR ABIERTO
PROTECCION DELANTERA
RODILLO Ø 195
PATINES
DESPLAZAMIENTO LAT. HYDRAULICO
INCLINACION HYDRAULICA CON
VALVULA DE BLOQUEO
RUEDA LIBRE EN LOS ENGRANAJES
CONJERE OSCILANTE DOBLE RODILLO



PRESTIGE 210

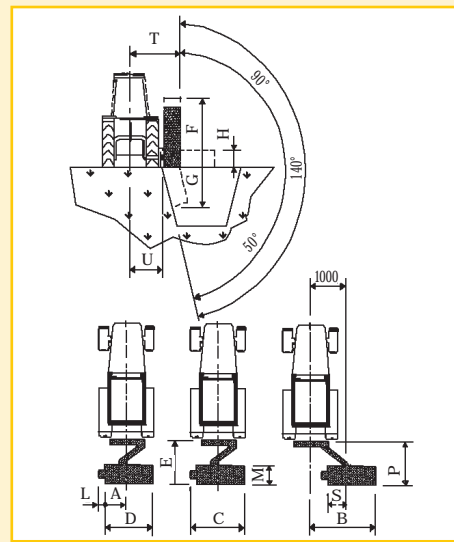

BIELLA DI SICUREZZA E AUTOLIVELLAMENTO
 SAFETY AND SELF-LEVELLING / BREAKAWAY
 COUPLING / BIELLE DE SÉCURITÉ
 ET AUTO-NIVELLEMENT / ANFAHRSSICHERUNG
 UND BODENANGLEICH DURCH
 PLEUELSTANGE / BIELA DE SEGURIDAD
 Y AUTONIVELACION



PRESTIGE 160



PRESTIGE 235



DISPOSITIVO ANTI-SHOCK OLEOPNEUMATICO
 OLEOPNEUMATIC ANTI-SHOCK DEVICE
 DISPOSITIF OLEOPNEUMATIQUE ANTI-CHOC
 HYDROPNEMATISCH ANFAHRTSSICHERUNG
 SISTEMA ACEITENEUMATICO CONTRAGOLPE



OPTIONAL: PRESTIGE-O-S
 DISPOSITIVO ANTI-SHOCK OLEOPNEUMATICO
 OLEOPNEUMATIC ANTI-SHOCK DEVICE
 DISPOSITIF OLEOPNEUMATIQUE ANTI-CHOC
 HYDROPNEMATISCH ANFAHRTSSICHERUNG
 SISTEMA ACEITENEUMATICO CONTRAGOLPE